

# GREENLINE

Pioneer Prime Diesel-Driven Centrifugal Pump

# PP66S12L71-1104D44T-GL2



## PUMP SPECIFICATIONS

Size	6" x 6" (150 x 150 mm)
Max Flow	3,400 gpm (772 m <sup>3</sup> /h)
Max Head	200 feet (61 meters)
Solids Size	3" (76 mm)

## ENGINE SPECIFICATIONS

Engine Type	Perkins (T3) 1104D44T, 4-Cylinder Diesel, Tier 3
Displacement	267 cu. in. (4.4 l)
Fuel Consumption @ 1800 RPM	4.2 gph (16 l/h) (full load)
Continuous HP	78 HP @ 1800 rpm
Safety Shut Down Switches	Low oil pressure, high temperature, and v-belt failure
Instrument Panel	Oil pressure gauge, ampmeter, hourmeter, and tachometer

## ULTRAPRIME™ PRIMING SYSTEM

Priming System	Mech. driven diaphragm-style vacuum pump
Air Removal Capability	50 cfm
Priming Chamber	Positive sealing air separation PosiValve™ w/SS float ball & linkage
Discharge Check Valve	Swing style; ductile iron w/nitrile disc
Run Dry System	Oil-lubricated mech. seal allows pump to run completely dry w/o damage

## FEATURES

- Indefinite run-dry capability
- Extreme flow technology
- Environmentally safe priming system with patented PosiValve™
- Auto-start controls

## SPECIFICATIONS

Control Panel	Murphy MPC-10
Dimensions (L x W x H)	86 x 45 x 61
Fuel Capacity	75 gallons
Runtime (hours)	17.8 hours
Other Specifications	Vibration isolated, lifting bail, leak-proof diesel cap, analog fuel gauge, tank clean-out, drip pan drain
SAE	SAE engine-mount bracket options available

## MATERIALS OF CONSTRUCTION

Material	Standard Construction
Impeller	CA6NM SS
Shaft	17-4 PH
Wear Ring	Gray Iron
Suction Cover	Ductile Iron
Volute	Ductile Iron
Brac-Plate/Bracket	Ductile Iron
Mechanical Seal	Tungsten vs. Silicon Carbide

## MECHANICAL DIMENSIONS

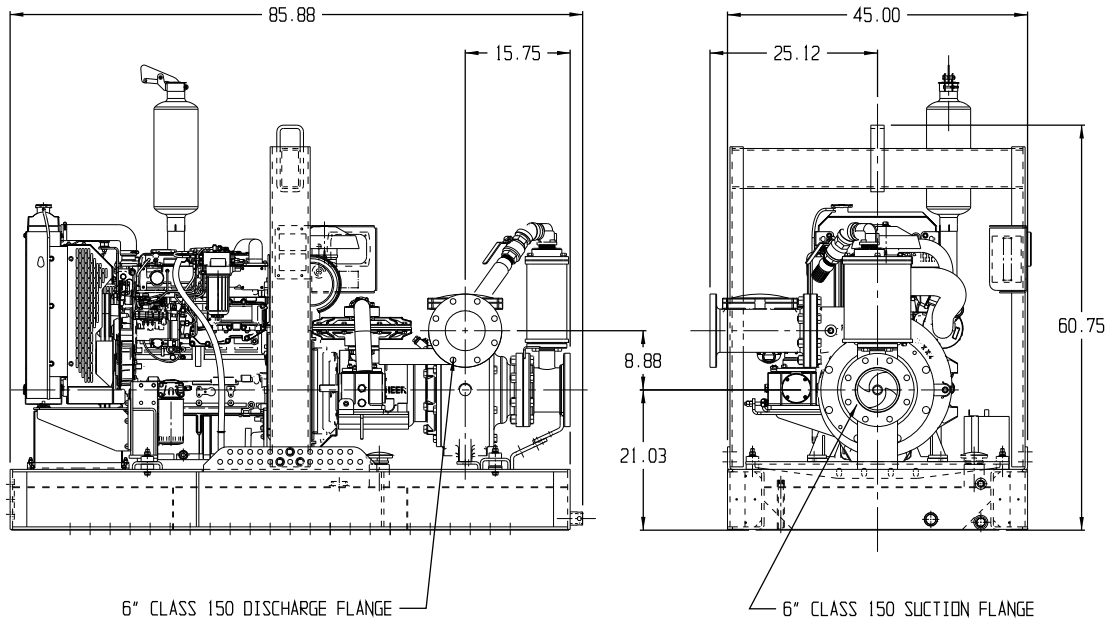

## PERFORMANCE CURVE

Model: PP66S12

Impeller Dia: 11"

Solids Size: 3"

Curve #A928HQ

